

Are we there yet?



A Free Project Sheet
NOT FOR RESALE

By *Barbara Jones*

Quilt Design by Heidi Pridemore



Quilt 2

Skill Level: Advanced Beginner

A Free Project Sheet From



Finished Quilt Size: 53" x 63"
49 West 37th Street, New York, NY 10018
tel: 212-686-5194 fax: 212-532-3525
Toll Free: 800-294-9495
www.henryglassfabrics.com

ARE WE THERE YET?

Finished Quilt Size: 53" x 63"

Quilt 2

Fabrics in the Collection



Panel - Multi
6767P-11

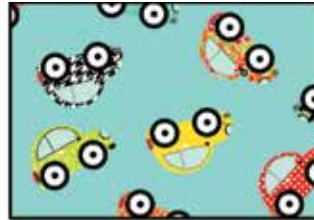

Cars - Blue
6768-11



Cars - Red
6768-88

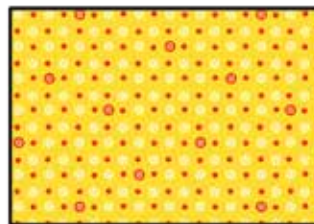

Dots - Yellow
6769-44

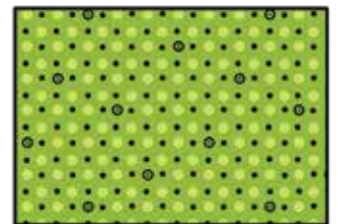

Dots - Green
6769-66



Dots - Red
6769-88



Houndstooth - Green
6770-66

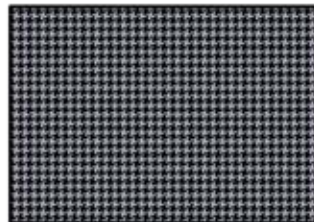

Houndstooth - Black
6770-99



Signs - Multi
6771-6



Floral - Yellow
6772-44



Floral - Red
6772-88



Floral - Black
6772-99



Gas Pumps - Green
6773-66



Geometric - Aqua
6774-11



Geometric - Orange
6774-33



Novelty Stripe - Multi
6775-11

Select Fabrics from
Modern Melody Basics
Collection



Pigment White
1063-01W



Brown
1063-33



Black
1063-99

Materials

1 panel	Panel - Multi (A)	6767P-11
3/4 yard	Modern Melody Basics - Black (B)	1063-99
1/8 yard	Floral - Red (C)	6772-88
1/3 yard	Signs - Multi (D)	6771-6
2/3 yard	Houndstooth - Black (E)	6770-99*
1/8 yard	Geometric - Aqua (F)	6774-11
1/8 yard	Dots - Green (G)	6769-66
1/8 yard	Floral - Yellow (H)	6772-44
1/8 yard	Dots - Yellow (I)	6769-44
1/2 yard	Geometric - Orange (J)	6774-33
1/8 yard	Dots - Red (K)	6769-88
1/8 yard	Gas Pumps - Green (L)	6773-66
1 1/8 yards	Cars - Blue (M)	6768-11
1/2 yard	Modern Melody Basics - Pigment White (N)	1063-01W
3 1/2 yards	Cars - Red (Backing)	6768-88

*Includes binding

Cutting Instructions

Please note: all strips are cut across the width of fabric (WOF) from selvage to selvage edge unless otherwise noted.

From the Panel - Multi (A), fussy cut:

- (15) 7 1/2" blocks.

From the Modern Melody Basics - Black (B), cut:

- (6) 1 1/2" x WOF strips. Sub-cut strips into (30) 1 1/2" x 7 1/2" strips.
- (8) 1 1/2" x WOF strips. Sub-cut strips into (30) 1 1/2" x 9 1/2" strips.

From the Floral - Red (C), cut:

- (1) 2 1/2" x WOF strip. Sub-cut strip into (10) 2 1/2" squares.

From the Signs - Multi (D), cut:

- (1) 7 1/2" x WOF strip. Sub-cut strip into (5) 7 1/2" squares.

From the Houndstooth - Black (E), cut:

- (2) 1" x WOF strips. Sub-cut strips into (10) 1" x 7 1/2" strips.
- (3) 1" x WOF strips. Sub-cut strips into (10) 1" x 8 1/2" strips.
- (6) 2 1/2" x WOF strips for the binding.

From the Geometric - Aqua (F), cut:

- (1) 2 1/2" x WOF strip. Sub-cut strip into (13) 2 1/2" squares.

From the Dots - Green (G), cut:

- (1) 2 1/2" x WOF strip. Sub-cut strip into (5) 2 1/2" squares.

From the Floral - Yellow (H), cut:

- (1) 2 1/2" x WOF strip. Sub-cut strip into (9) 2 1/2" squares.

From the Dots - Yellow (I), cut:

- (1) 2 1/2" x WOF strip. Sub-cut strip into (13) 2 1/2" squares.

From the Geometric - Orange (J), cut:

- (1) 2 1/2" x WOF strip. Sub-cut strip into (9) 2 1/2" squares.
- (5) 2" x WOF strips. Sew the strips together end to end with diagonal seams and cut (2) 2" X 50 1/2" strips and (2) 2" x 43 1/2" strips.

From the Dots - Red (K), cut:

- (1) 2 1/2" x WOF strip. Sub-cut strip into (13) 2 1/2" squares.

From the Gas Pumps - Green (L), cut:

- (1) 2 1/2" x WOF strip. Sub-cut the strip into (9) 2 1/2" squares.

From the Cars - Blue (M), cut:

- (1) 2 1/2" x WOF strip. Sub-cut the strip into (9) 2 1/2" squares.
- (6) 5 1/2" x WOF strips. Sew the strips together end to end with diagonal seams and cut (4) 5 1/2" x 53 1/2" strips.

From the Modern Melody Basics - Pigment White (N), cut:

- (6) 2 1/2" x WOF strips. Sub-cut strips into (90) 2 1/2" squares.

From the Cars - Red (Backing), cut:

- (2) 61" x WOF strips for the backing. Sew the strips together and trim to make the 61" x 71" back.

Sewing Instructions

1. Sew (1) 1 1/2" x 7 1/2" Fabric B strip to each side of (1) 7 1/2" Fabric A block. Sew (1) 1 1/2" x 9 1/2" Fabric B strip to the top and to the bottom of the Fabric A block. Trim the block to measure 8 1/2" square to make (1) Unit 1 block (Fig. 1). Repeat to make (15) Unit 1 blocks total.

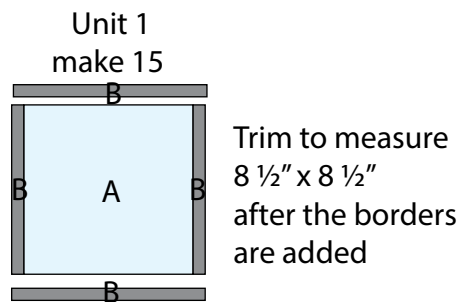

Fig. 1

ARE WE THERE YET?

Quilt 2

2. Sew (1) 1" x 7 1/2" Fabric E strip to each side of (1) 7 1/2" Fabric D square. Sew (1) 1" x 8 1/2" Fabric E strip to the top and to the bottom of the Fabric D square to make (1) Unit 2 block (Fig. 2). Repeat to make (5) Unit 2 blocks total.

3. Sew (2) 2 1/2" Fabric C squares and (2) 2 1/2" Fabric N squares together, alternating them. Sew this strip to the left side of (1) Unit 1 block. Sew (3) 2 1/2" Fabric C squares and (2) 2 1/2" Fabric N squares together, alternating them. Sew this strip to the top of the Unit 1 block to make (1) Block One (Fig. 3). Repeat to make a second Block One.

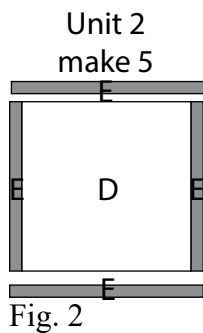

Fig. 2

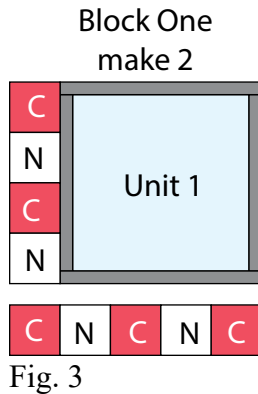

Fig. 3

4. Repeat Step 3 and use Figures 4 through 21 for fabric identification and location to sew the appropriate 2 1/2" squares to the remaining Unit 1 blocks and the Unit 2 blocks.

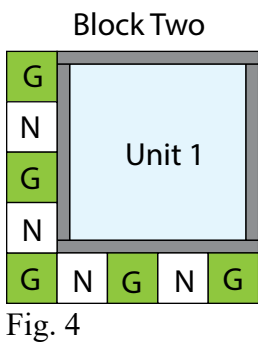

Fig. 4

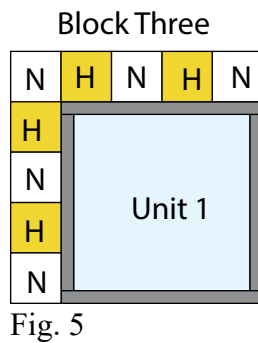

Fig. 5

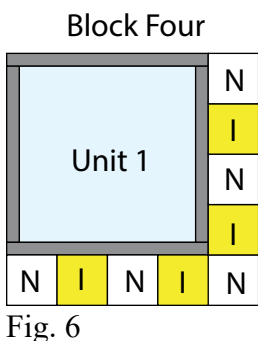

Fig. 6

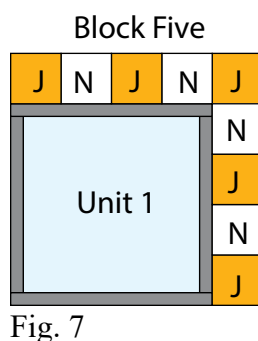

Fig. 7

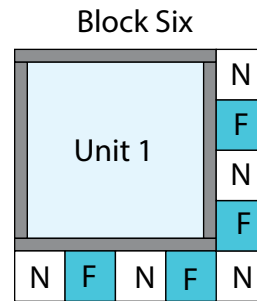

Fig. 8

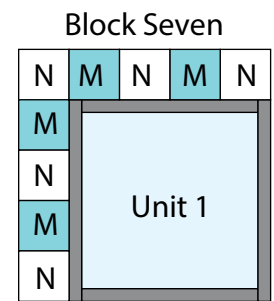

Fig. 9

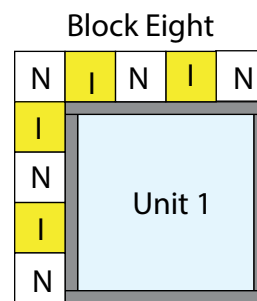

Fig. 10

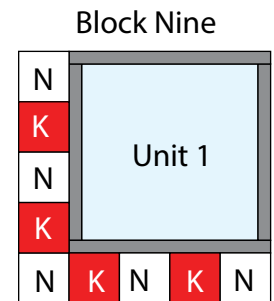

Fig. 11

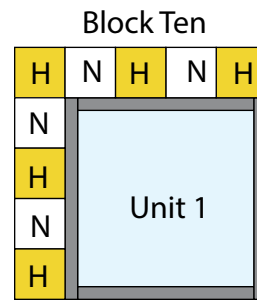

Fig. 12

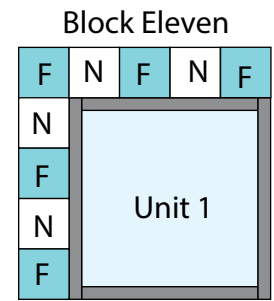

Fig. 13

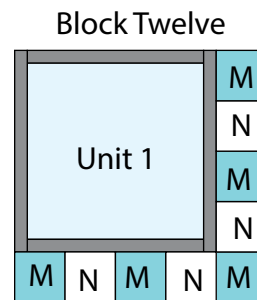

Fig. 14

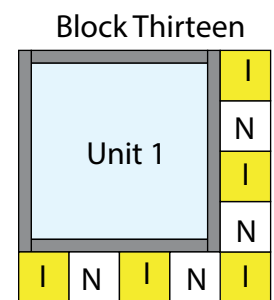

Fig. 15

Block Fourteen

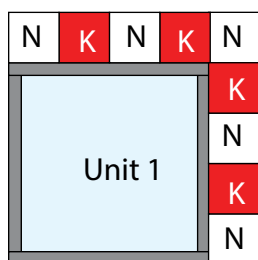

Fig. 16

Block Fifteen

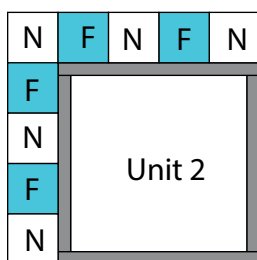

Fig. 17

Block Sixteen

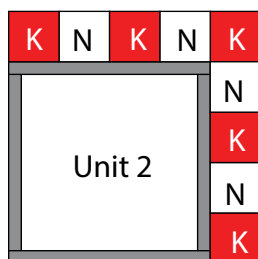

Fig. 18

Block Seventeen

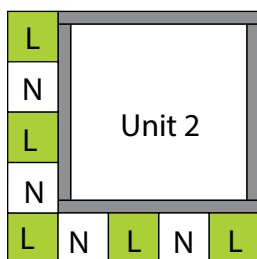

Fig. 19

Block Eighteen

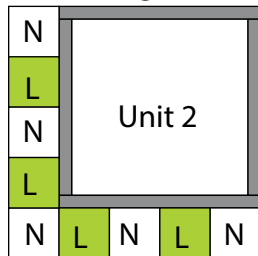

Fig. 20

Block Nineteen

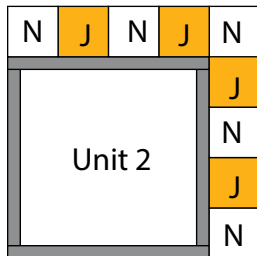

Fig. 21

Quilt Top Assembly

(Refer to the Quilt Layout while assembling.)

5. Sew (4) assorted blocks together to make (1) row. Repeat to make (5) rows total.
6. Sew the (5) rows together to make the Center Block.
7. Sew (1) 2" x 50 1/2" Fabric J strip to each side of the Center Block. Sew (1) 2" x 43 1/2" Fabric J strip to the top and to the bottom of the Center Block.
8. Sew (1) 5 1/2" x 53 1/2" Fabric M strip to each side of the Center Block. Sew (1) 5 1/2" x 53 1/2" Fabric M strip to the top and to the bottom of the Center Block to make the quilt top.
9. Layer and quilt as desired.
10. Sew the (6) 2 1/2" x WOF Fabric E strips together, end to end with 45-degree seams, to make the binding. Fold this long strip in half lengthwise with wrong sides together and press.
11. Bind as desired.

ARE WE THERE YET? Quilt 2

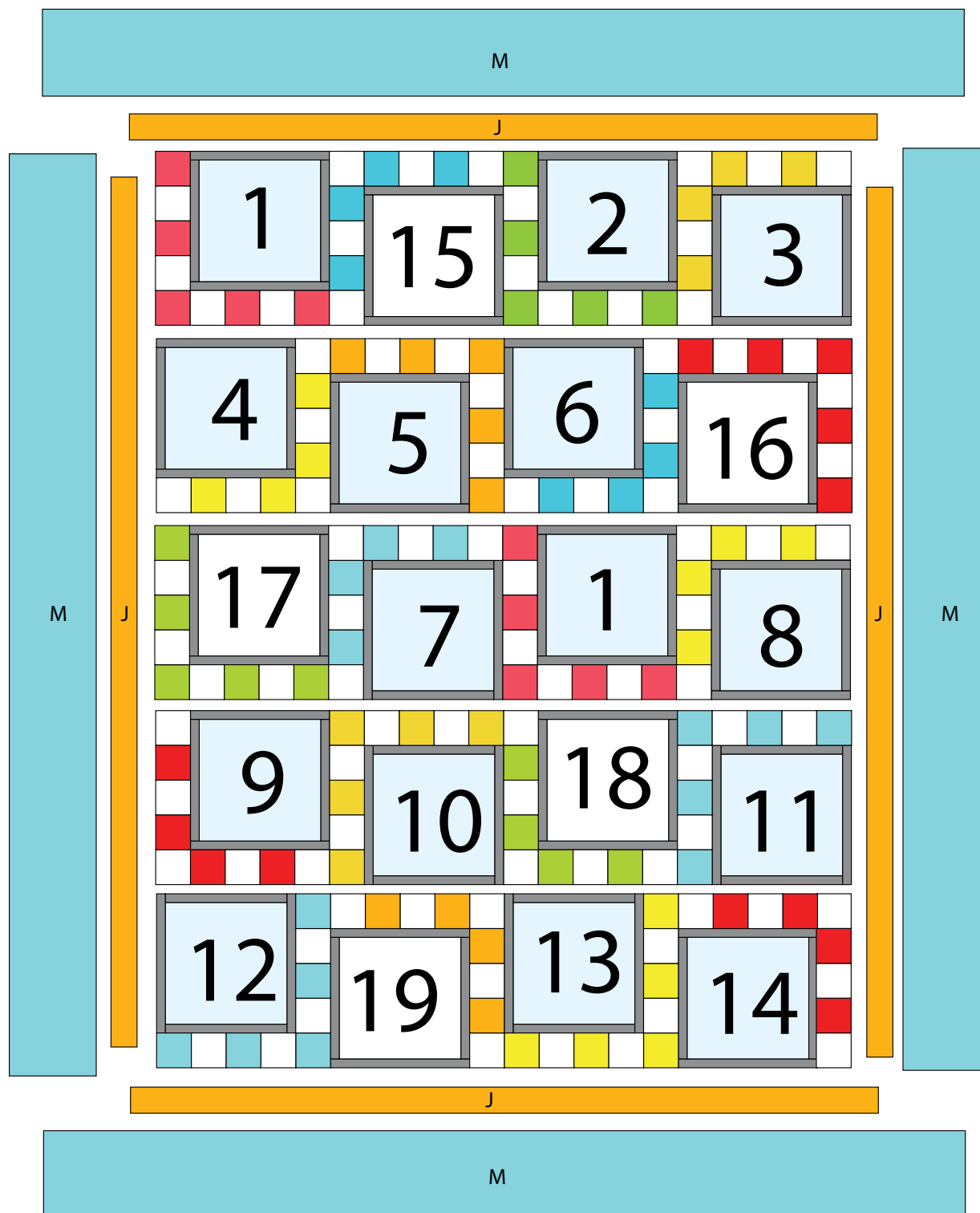

Quilt Layout

Every effort has been made to ensure that all projects are error free. All the information is presented in good faith, however no warranty can be given nor results guaranteed as we have no control over the execution of instructions. Therefore, we assume no responsibility for the use of this information or damages that may occur as a result. When errors are brought to our attention, we make every effort to correct and post a revision as soon as possible. Please make sure to check www.henryglassfabrics.com for pattern updates prior to starting the project. We also recommend that you test the project prior to cutting for kits. Finally, all free projects are intended to remain free to you and are not for resale.